

SP80 and SP80H user's guide

www.renishaw.com

SP80 and SP80H user's guide

Document part number: H-1000-5213-06-A



SP80 and SP80H user's guide

www.renishaw.com

General information

© 2011 - 2022 Renishaw plc. All rights reserved.



This document may not be copied or reproduced in whole or in part, or transferred to any other media or language by any means, without the prior written permission of Renishaw.

Disclaimer

WHILE CONSIDERABLE EFFORT WAS MADE TO VERIFY THE ACCURACY OF THIS DOCUMENT AT PUBLICATION, ALL WARRANTIES, CONDITIONS, REPRESENTATIONS AND LIABILITY, HOWSOEVER ARISING, ARE EXCLUDED TO THE EXTENT PERMITTED BY LAW.

RENISHAW RESERVES THE RIGHT TO MAKE CHANGES TO THIS DOCUMENT AND TO THE EQUIPMENT, AND/OR SOFTWARE AND THE SPECIFICATION DESCRIBED HEREIN WITHOUT OBLIGATION TO PROVIDE NOTICE OF SUCH CHANGES.

Trade marks

RENISHAW®, the probe symbol and REVO® are registered trade marks of Renishaw plc.

Renishaw product names, designations and the mark 'apply innovation' are trade marks of Renishaw plc or its subsidiaries.

Other brand, product or company names are trade marks of their respective owners.

WEEE



The use of this symbol on Renishaw products and / or accompanying documentation indicates that the product should not be mixed with general household waste upon disposal. It is the responsibility of the end user to dispose of this product at a designated collection point for waste electrical and electronic equipment (WEEE) to enable reuse or recycling. Correct disposal of this product will help to save valuable resources and prevent potential negative effects on the environment. For more information, please contact your local waste disposal service or Renishaw distributor.

Warranty

Unless you and Renishaw have agreed and signed a separate written agreement, the equipment and/or software are sold subject to the Renishaw Standard Terms and Conditions supplied with such equipment and/or software, or available on request from your local Renishaw office.

Renishaw warrants its equipment and software for a limited period (as set out in the Standard Terms and Conditions), provided that they are installed and used exactly as defined in associated Renishaw documentation. You should consult these Standard Terms and Conditions to find out the full details of your warranty.

Equipment and/or software purchased by you from a third-party supplier is subject to separate terms and conditions supplied with such equipment and/or software. You should contact your third-party supplier for details.

SP80 and SP80H user's guide

www.renishaw.com

Care of equipment

Renishaw probes and associated systems are precision tools used for obtaining precise measurements and must therefore be treated with care.

Changes to Renishaw products

Renishaw reserves the right to improve, change or modify its hardware or software without incurring any obligations to make changes to Renishaw equipment previously sold.

Company registration details

Renishaw plc. Registered in England and Wales. Company no: 1106260. Registered office: New Mills, Wotton-under-Edge, Gloucestershire, GL12 8JR, UK.

Packaging

To aid end user recycling and disposal the materials used in the different components of the packaging are stated here:

Packaging component	Material	94/62/EC code	94/62/EC number
Packing foam	Low density polyethylene	LDPE	04
Outer box	Corrugated fibreboard	PAP	20
Bag	High density polyethylene	HDPE	02

Patents

Features of Renishaw's SP80 system and associated products are the subjects of one or more of the following patents and patent applications:

CN100460814	EP1495282	US7055258
	EP1792139	US7526873
		USRE40578

SP80 and SP80H user's guide

www.renishaw.com

Product compliance

EU declaration of conformity

Contact Renishaw plc or visit www.renishaw.com/EUCMM for the full EU declaration.

UK declaration of conformity

Contact Renishaw plc or visit www.renishaw.com/UKCMM for the full UK declaration.

EMC conformity

This equipment must be installed and used in accordance with this installation guide. This product is intended for industrial use only and should not be used in a residential area or connected to a low voltage power supply network which supplies buildings used for residential purposes.

FCC (USA only)

Information to user (47 CFR 15.105)

This equipment has been tested and found to comply with the limits for a Class A digital device, pursuant to Part 15 of the FCC rules. These limits are designed to provide reasonable protection against harmful interference when the equipment is operated in a commercial environment. This equipment generates, uses, and can radiate radio frequency energy and, if not installed and used in accordance with the instruction manual, may cause harmful interference to radio communications. Operation of this equipment in a residential area is likely to cause harmful interference, in which case you will be required to correct the interference at your own expense.

Information to user (47 CFR 15.21)

The user is cautioned that any changes or modifications not expressly approved by Renishaw plc or authorised representative could void the user's authority to operate the equipment.

Equipment label (47 CFR 15.19)

This device complies with part 15 of the FCC Rules. Operation is subject to the following two conditions:

1. This device may not cause harmful interference.
 2. This device must accept any interference received, including interference that may cause undesired operation.
-

SP80 and SP80H user's guide

www.renishaw.com

ICES-001 (Canada only)

This ISM device complies with Canadian ICES-001(A) / NMB-001(A).

Cet appareil ISM est conforme à la norme ICES-001(A) / NMB-001(A) du Canada.

REACH regulation

Information required by Article 33(1) of Regulation (EC) No. 1907/2006 ("REACH") relating to products containing substances of very high concern (SVHCs) is available at:

www.renishaw.com/REACH

China RoHS

Contact Renishaw plc or visit www.renishaw.com/ChinaRoHSCMM for the full China RoHS tabulation.



SP80 and SP80H user's guide

www.renishaw.com

Safety

There is no overtravel protection in the +Z axis other than an end stop. The control system must therefore be able to stop the motion of the machine in the +Z axis of the probe before the endstop is reached. If this is not the case, safety glasses must be worn when operating or observing the operation of the SP80 and SP80H system to avoid injury in the case of stylus breakage.

Machine operators must be trained in the use and application of the SP80 and SP80H in the context of the machine it is fitted to before being allowed to operate that machine.



CAUTION: Permanent magnets are used in some components of the SP80 and SP80H system. It is important to keep them away from items which may be affected by magnetic fields, e.g. data storage systems, pacemakers and watches etc.

SP80 and SP80H user's guide

www.renishaw.com

System overview

The SP80 system comprises the SP80 or SP80H ultra-high accuracy scanning probe, the probe interface and a rack system for stylus holder changing.

The SP80 and SP80H are fixed type scanning probes that use digital scale and readhead technology (with 0.02 µm measuring resolution), and features Renishaw's innovative isolated optical metrology principles, to provide exceptional scanning performance, even with long styli. The simple and robust passive design has no internal motors to generate heat or reliability issues and therefore unnecessary system complexity is avoided. The difference between the SP80 and SP80H is that the SP80H has a different spring arrangement to allow it to be mounted horizontally.

The probe is able to access features deep within parts by carrying styli up to 800 mm long* and 500 g mass**, including star configurations which do not require counterbalancing. Renishaw's range of M5 styli products are designed to complement SP80 and ensure peak performance.

Detachable stylus holders (SH80) permit rapid and repeatable interchange between stylus configurations thus eliminating re-calibration, maximising productivity and permitting optimum solutions to match the application. The stylus holders also provide crash protection in the probe X Y direction and a bump stop prevents damage to the probe in the probe Z-axis.

The SH80K is a detachable stylus holder that when fitted allows both the SP80 and the SP80H to be powered off without the need to re-home the probe on power up.

To allow easy, manual removal and fitment of stylus holders, an SH80 removal tool is provided as part of the standard probe kit.

The SP80 and SP80H have kinematic mounts that offer a repeatable connection to the quill mounting plate (KM80), allowing the probe to be easily removed from the co-ordinate measuring machine (CMM). The KM80 is designed for a 80 mm × 80 mm quill. Alternative mounting plates are provided to suit a 60 mm x 60 mm quill (KM6080) or the non-preferred shank mounted installations (SM80). These mounts are compatible with both the SP80 and the SP80H.

There are two types of stylus change ports to provide rapid automatic changing between stylus holders. The SCP80, for use with the SP80 probe, is mounted to Renishaw's modular rack system (MRS). The SCP80V, for use with the SP80H probe, can be mounted to the MRS for use with SP80 but there is no equivalent configuration for a vertically mounted rack. It is the OEM's responsibility to provide this. The difference between the two ports is that the SCP80V uses a different spring arrangement to provide the higher force needed for the return forks when the rack is in the vertical orientation. This different spring arrangement also makes it possible for the SCP80V to be used with SP80 when using long styli that extend through the rear of the port, this will ensure that the port returns to its home position.



NOTE: The MRS mounts on the CMM table and comprises a length selectable horizontal rail, with height adjustable legs. It carries stylus changer units for several Renishaw probe systems as well as the ACR3 autochange rack. No equivalent is available for the vertically mounted SCP80V. It is the OEM's responsibility to provide this.

* Longer stylus lengths may be carried subject to operating conditions - consult Renishaw for application assistance.

** This applies to SP80, SP80H has different limits, refer to SP80H stylus carrying capability for details.

SP80 and SP80H user's guide

www.renishaw.com

Probe kit

The SP80 and SP80H probe kits contain the main components detailed below, together with a probe cable, tools and a stylus.

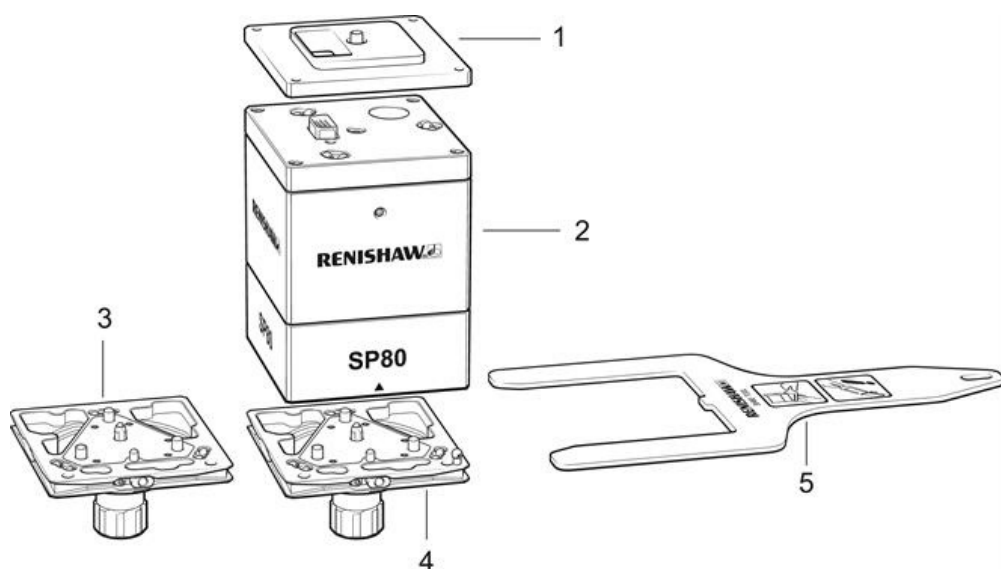

Key	Description
1	KM80 kinematic quill mount plate (to suit 80 mm × 80 mm CMM quills)
2	SP80 or SP80H probe body
3	SH80 stylus holder
4	SH80K
5	SH80 removal tool

KM80 kinematic quill mount plate

The SP80 and SP80H mount on the 80 mm × 80 mm quill of a CMM using the KM80 kinematic quill mount plate. The KM80 is attached to the end of the quill, and the probe is subsequently mounted to the KM80 via a kinematic joint and quick release autojoint locking mechanism.

KM6080 quill mount adaptor plate

The KM6080 is an adaptor plate that attaches to a 60 mm × 60 mm quill, but converts the 'footprint' to 80 mm × 80 mm to allow fitment of the SP80 and SP80H. It is not supplied with the standard probe kits and must be ordered separately.

SP80 and SP80H user's guide

www.renishaw.com

SM80 shank mount adaptor plate

The SM80 shank adaptor plate is an option when the KM80 or KM6080 cannot be used, e.g. retrofit of a CMM. It is not supplied with the standard probe kits and must be ordered separately. The SM80 accepts any standard Renishaw shank and converts the output connector of the SP80 and SP80H to a touchel connector on the rear of the mount.



CAUTION: Poor shank mounting can impair measuring accuracy and therefore this mounting method should be avoided wherever possible.

SP80 and SP80H probe body

The SP80 and SP80H scanning probe bodies are designed for use on direct computer controlled (DCC) CMMs. Direct fitting of the probe to the quill using the KM80 is beneficial for ultimate metrology performance, and for simple fitment to the CMM. The probe uses standard probe head cabling (so there is no requirement for new or extra cabling within the CMM).

The SP80 and SP80H design builds on the passive scanning technology of the SP600 family, but features digital scale and readheads. This enables exceptional high-accuracy scanning performance, even with long styli and extensions up to 500 mm long* and 500 g mass**. Star styli do not need to be counterbalanced, and travel in each axis is ± 2.5 mm for SP80 and for SP80H is $PX^{***} \pm 1.25$ mm and PY^{***} and $PZ^{***} \pm 2.5$ mm.

The sensor mechanism, in both probe types, comprises an arrangement of three sets of parallel springs, one for each body axis, set in a cube - hence the body shape. The motion of the stylus is coupled to a 'moving cube' holding graduated reflective scales - again one for each axis. The readheads are mounted on the wall of the probe and the light projected from them is reflected from the moving cube. This arrangement is known as the 'isolated optical metrology' principle, which is described in more detail in section - [Isolated optical metrology principle](#). The motion detection system does not require any form of moving wire.

Interchangeable stylus holders (SH80) feature a repeatable mount to the probe body and permit use of the optimised measuring solution to suit the application. Automatic stylus changing of SH80s is provided by stylus changing ports (SCP80 or SCP80V).

An LED on the front face of the probe provides a visual indication of the probe status. The LED will illuminate green when power is supplied to the probe. This LED may be switched off by the user if not required and the LED colour and mode is also user configurable (the options being green, red, or both together resulting in orange).

* Longer stylus lengths may be carried subject to operating conditions - consult Renishaw for application assistance.

** Restrictions apply for SP80H see [SP80H stylus carrying capability](#) for detail.

*** Where P specifies that it is the probe's axis rather than the machine's.

SP80 and SP80H user's guide

www.renishaw.com

Air supply

SP80 and SP80H units built after September 2010 have the ability to fit the air purge option. From this date all new probes have been supplied with a suitable push fit connector as part of the standard probe kit.

The SP80 and SP80H probes are supplied with a blanked off air purge hole. If the probe is to be operated in an environment where oil mist or other heavy vapours are present it is essential that an air supply is used to maintain positive purging of any contamination from the interior of the probe.

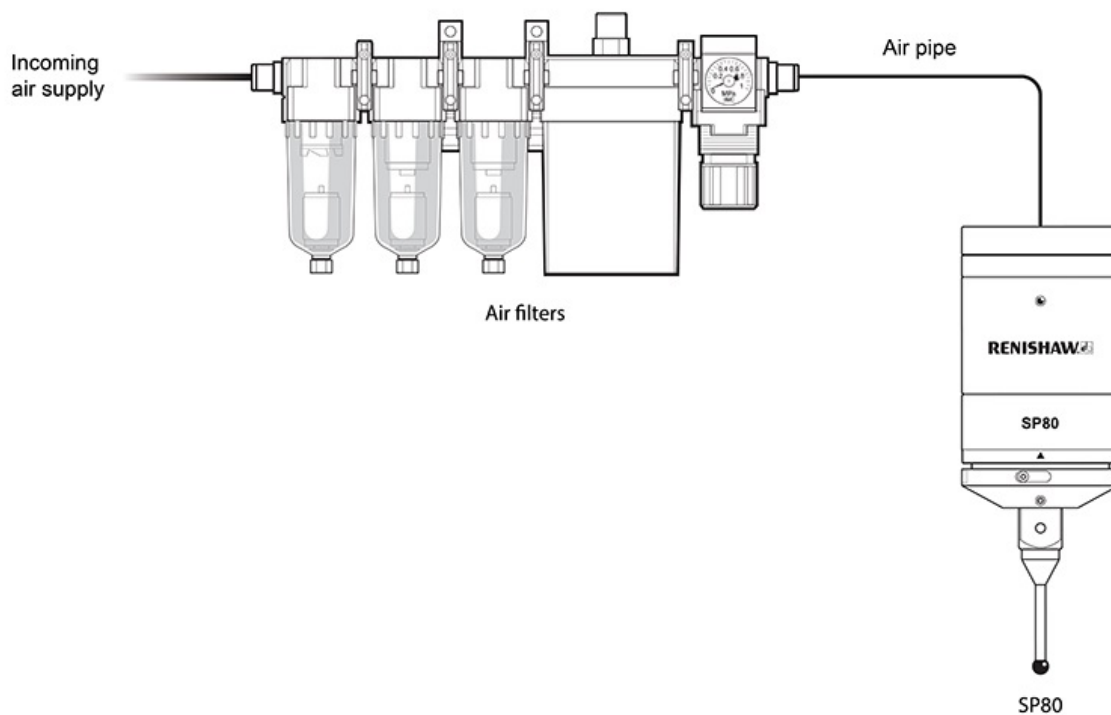

The air purge system requires an air filter. This can be purchased directly from Renishaw (Renishaw part number A-3060-0070) or a suitable alternative can be used.

Air filter maintenance



WARNING: It is vital that the air filters used for SP80 and SP80H air purge meet the specification detailed below and that the filter unit is maintained to the manufacturer's specification.

SP80 and SP80H user's guide

www.renishaw.com

To maintain the air quality:

1. Ensure the air provided to the filtration system meets the specification given.

Incoming air supply specification:

Air pressure	1 to 2 bar*
Air consumption	15 to 25 litres per minute
BS ISO 8537-1:2010 [4:4:4]	
Particle size	15 µm
Dirt concentration	8 mg / m ³
Dew point	+3 °C
Oil	5 mg / m ³



***NOTE:** The exact values are dependent on the inherent characteristics of the air pipe between the air filters and the SP80 / SP80H. Higher flow rates should be avoided as this could impair metrology. Please ask the installer for the specification. It is important that the air supply to the probe is maintained to ensure that the positive purging is effective.

2. Regularly monitor the dew point indicator (see image below) and follow the instructions given in the table.

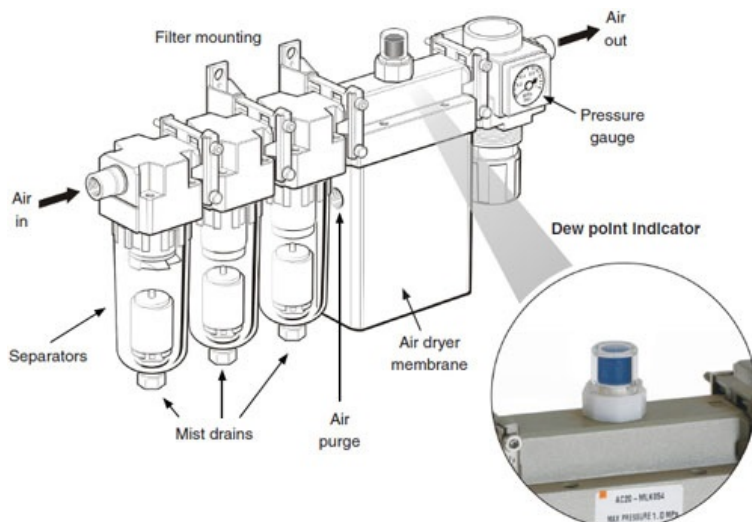

For more information please visit the air filtration manufacturer's website <http://www.smc pneumatics.com> and search for IDG5 filters. (Please refer to the section 'Air filter service kits' for details on air filter service kit part numbers).

SP80 and SP80H user's guide

www.renishaw.com

Dew point indications and maintenance instructions

Grain colour	Causes	Solutions
Blue / green	Normal operation.	No action required.
Pink / yellow	Water and oil flow into membrane air dryer.	1) Check and replace filters if necessary. 2) Check condition of inlet air for excess oil or water.

 **NOTE:** The grains may be pink / yellow on delivery and can take up to 1½ hours to turn blue / green when air is connected.

 **NOTE:** When dew point indicator absorbs vapourised oil content or other gaseous components in the compressed air, it may turn a colour other than blue / green or pink / yellow.

Air filter service kits

The Renishaw filter service kit (M-3060-0933) contains:

SMC part number	Description	Quantity
AF20P-060S	5 µm filter element for use with AF20 unit	1
AFM20P-060AS	0.3 µm filter element for use with AFM20 unit	1
AFD20P-060AS	0.01 µm filter element for use with AFD20 unit	1

We recommend that the above filter kit is replaced every two years.

The Renishaw membrane dryer service kit (M-3060-0943) contains:

SMC part number	Description	Quantity
IDG-EL5	Membrane module kit for use with IDG5 unit	1
IDG-DP01	Dew point indicator kit for use with IDG5 unit	1

We recommend that the above filter kit is replaced every four years.

SP80 and SP80H user's guide

www.renishaw.com

SH80 stylus holder

The SH80 stylus holder is located onto the probe body using a repeatable magnetic kinematic joint. It provides rapid interchange between stylus configurations thus enabling optimisation of measuring solutions to suit the application whilst maintaining system accuracy.

The SH80 features a 5-way cube for attachment of M5 styli. For additional flexibility, this cube may be rotationally adjusted for infinite angular positioning of the stylus. It is locked in the desired position by a single grub screw and does not need to be removed from the probe body to make the adjustment.

The SH80 can be automatically removed and replaced on the probe body by using a SCP80/V mounted on an MRS or suitable extrusion.

SH80's design makes it possible to dock into an SCP80 port which is aligned with any of the four sides of the SP80 probe. This enables the SCP80 / SCP80V system to be positioned to the rear, front, left or right of the CMM, or any combination of these. The user must fit the magnet keeper plate assembly to the side of the SH80 that will enter into the SCP80 / SCP80V port.

SH80 docking arrangements:

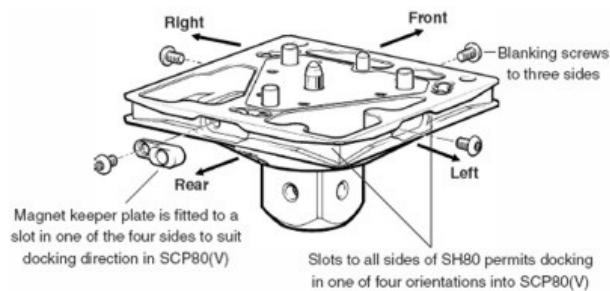

Engraved graduations assist visual orientation of the stylus cube, and four engraved alignment marks (▼►●■) are positioned on the SH80 and the corresponding sides of the probe body. The triangular mark indicates the front of the probe body.

Stylus changing offers crash protection by either the module becoming detached on collision or by setting a high deflection to alert the CMM of an unexpected collision. As with the SP600, the robustness of the probe means that a simple re-qualification of the probe and stylus arrangement should allow work to continue immediately.

SH80 markings:

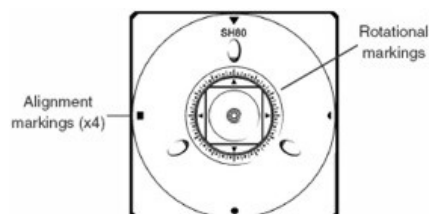

SP80 and SP80H user's guide

www.renishaw.com

SH80K

The SP80 and SP80H do not use absolute encoders. Therefore, when you power off the probe the encoder's position is not remembered. This means that when the probe is powered back on it is necessary to re-home the probe.

The SH80K is a device with a kinematic location ball that allows you to power off the SP80 and SP80H probes and turn it back on without needing to re-home the probe. This is achieved by fitting the SH80K before the power is switched off. The kinematic location ball locates into a kinematic location screw that is fitted to the probe and therefore holds the probe mechanism in a fixed position. This means that the readheads remain in a fixed position and therefore the probe does not need to be re-homed on power up.

The SH80K can be fitted to the probe either manually or automatically using an SCP80 / SCP80V.

It is possible to use SH80K with any SP80 or SP80H probe, providing you fit the kinematic location screw to the probe body.

i **NOTE:** If this screw is not fitted as standard it will be necessary to follow the instructions provided with SH80K and fit the kinematic location screw.

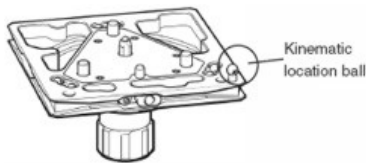

SP80 and SP80H user's guide

www.renishaw.com

Stylus change port

SCP80

The SCP80 stylus changing port enables automation of SH80 interchange onto the SP80 probe. It does not require any electrical connection for operation, and it fits to the MRS / MRS2. This provides simple flexibility to incorporate as many ports as required, whilst optimising working volume. The SCP80 has a spring-loaded mechanism that is designed to ease the stylus holder away from the probe body thus reducing the pull-off force to less than 20 N during the change cycle.

Two SCP80s mounted on an MRS / MRS2:

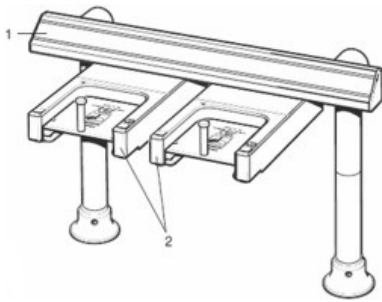

Key	Description
1	MRS / MRS2
2	SCP80

For some stylus configurations the SCP80V may be required, refer to [SCP80V stylus change port](#) page for further detail.

SP80 and SP80H user's guide

www.renishaw.com

SCP80V

The SCP80V stylus changing port enables automation of SH80 changing operation with the SP80H and long, rear orientated styli with SP80. It does not require any electrical connection for operation, and it fits to any standard extrusion. This provides simple flexibility to incorporate as many ports as required, whilst optimising working volume. The SCP80V has a spring-loaded mechanism that is designed to ease the stylus holder away from the probe body thus reducing the pull-off force to less than 20 N during the change cycle.

A Renishaw MRS system capable of mounting the SCP80V vertically for use with SP80H is not available. The mounting system should be provided by the OEM or end user.

SCP80V mounted on an OEM's mounting system for use with SP80H:

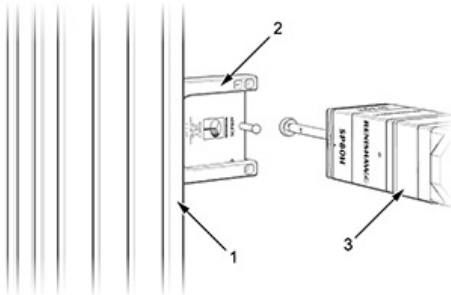

Key	Description
1	OEM's mounting system
2	SCP80V
3	SP80H

When using SP80 with styli that point to the rear of the port the SCP80V should be used.

SCP80V horizontally mounted to hold styli that are orientated to the rear of the rack port:

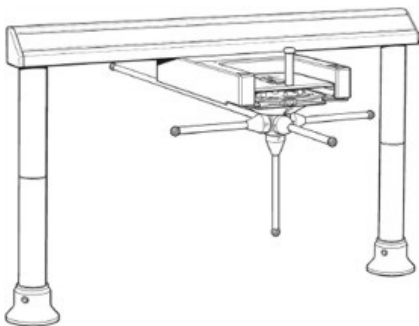

SP80 and SP80H user's guide

www.renishaw.com

IU80 interpolator unit

The IU80 interpolator unit is a free-standing interface for the SP80 and SP80H. It is required for installations where the UCC S3 controller and UCC PI 80 interface are not used. The IU80 is connected to the probe by the machine cable. The output of the IU80 is then transferred either to the CC6, or alternatively to an OEM controller via a Renishaw supplied unterminated cable.



SP80 and SP80H user's guide

www.renishaw.com

CC6 PCI counter card

The Renishaw CC6 counter card is a 5 V 32 bit PCI card. The card can be used to integrate the Renishaw SP80(H) probe when used in conjunction with the Renishaw IU80 interpolator unit.

The CC6 monitors the output of the probe via the IU80 and supplies the host PC with this information on request, via the PCI bus. The CC6 is small enough to fit neatly into a 5 V switching standard PCI slot inside the host PC without precluding the insertion of any other cards or impairing any required access to other components.

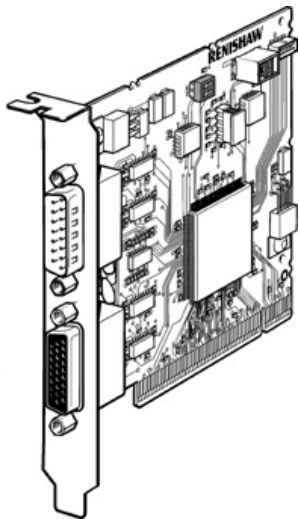

SP80 and SP80H user's guide

www.renishaw.com

Isolated optical metrology principle

Using an isolated optical metrology principle, the probe directly measures the deflection of the whole mechanism, thus providing outstandingly accurate position sensing.

The isolated optical metrology system can detect sources of variable error such as thermal and dynamic effects. By contrast, probes with displacement sensors mounted to stacked axes suffer from latency under changing inertial loads, and cannot detect thermal growth in their mechanisms.

Isolated optical metrology can be explained as a feature of the transducer system. The readheads for each axis are fixed to the body of the probe, and measure the deflection in each direction. Any inter-axis errors caused by the arc motion of each pair of parallel-acting springs are directly measured by the sensor system. Isolated optical metrology systems have no moving wire connections.

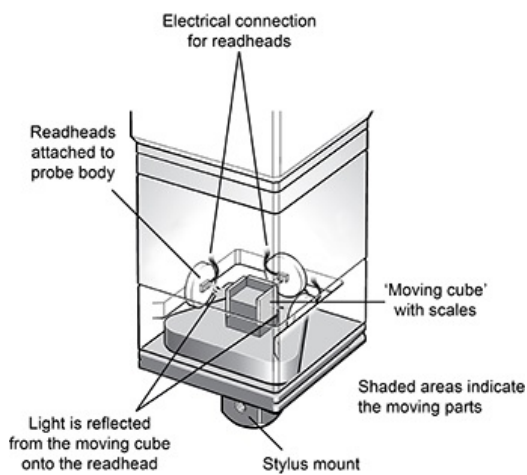

SP80 and SP80H user's guide

www.renishaw.com

Specification

SP80 probe system

The probe orientation shown below is the orientation used in the SP80 probe product specification.



SP80 and SP80H user's guide

www.renishaw.com

Probe attributes	Ultra-high accuracy scanning probe with three axis measurement ($\pm PX$, $\pm PY$, $\pm PZ$)*
Orientation	Vertical
Size	80 mm × 80 mm (3.15 in × 3.15 in) body, 150 mm (5.91 in) long including SH80 stylus holder
Quill mounting	KM80 - 80 mm × 80 mm quill to kinematic SP80 quill mount (standard) KM6080 - 60 mm × 60 mm quill to 80 mm × 80 mm kinematic SP80 probe mount (option) SM80 - shank mount and other custom made adaptor plates available - contact your Renishaw supplier for details
Measurement range	3-axis measurement: ± 2.5 mm (± 0.12 in) (PX, PY, PZ)*
Overtravel range	PX* and PY* protected by breakout of the kinematic joint to the SH80 PZ* has a mechanical 'bump-stop'
Resolution of digital scales	0.02 μ m
Measurement capability test to ISO10360-2**	Typically <1.0 μ m with a 50 mm stylus
Scanning capability test to ISO10360-4**	Typically <1.5 μ m MPETHN with a 50 mm stylus Time for typical scan = 74 s
Return to zero	Approximately 1% of working deflection
Spring rate	Approximately 1.8 N/mm (X, Y, Z)
Stylus carrying capability	Renishaw M5 stylus range Maximum 500 g mass (unbalanced) Maximum 1000 mm projection #
Mass	SP80 probe body only: 860 g SH80 stylus holder: 185 g KM80 quill mount: 110 g
Pull off force of SH80	<20 N when using SCP80 - otherwise approximately 80 N
Probe power supply	+9 V to +18 V @ 300 mA maximum dc
System power supply (including IU80)	+5 V ± 0.25 V @ 1 A maximum dc
SP80 probe outputs (PX, PY, PZ)*	1.5 V ± 0.25 V p-p. analogue quadrature signal (nominal 2.5 V zero crossing reference)
Interfacing options	<ul style="list-style-type: none"> Using a Renishaw PCI counter card (CC6) and the Renishaw interpolator unit (IU80) Other interface card designed by the OEM and used in conjunction with an IU80 Using a counter card and interpolator units designed by the OEM
Change rack system	SCP80 units mounted to MRS / MRS2 SCP80V units mounted to MRS / MRS2 for rear facing styli

SP80 and SP80H user's guide

www.renishaw.com

* Where P specifies that it is the probe axis rather than the machine

** Tested on a CMM with specification of $0.48 \mu\text{m} +L/1000$ with touch and scanning deflections $\leq 0.5 \text{ mm}$

Longer stylus lengths may be carried subject to operating conditions - consult Renishaw for application assistance

SP80H probe specification

The probe orientation shown below is the orientation used in the SP80H probe product specification.

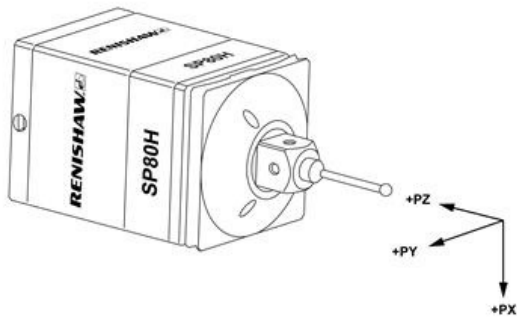

SP80 and SP80H user's guide

www.renishaw.com

Probe attributes	Ultra-high accuracy scanning probe with three axis measurement ($\pm PX$, $\pm PY$, $\pm PZ$)*
Orientation	Horizontal
Size	80 mm × 80 mm (3.15 in × 3.15 in) body, 150 mm (5.91 in) long including SH80 stylus holder
Quill mounting	KM80: 80 mm × 80 mm quill to kinematic SP80 quill mount (standard) KM6080: 60 mm × 60 mm to 80 mm × 80 mm kinematic SP80 probe mount (option) SM80 : Shank mount and other custom made adaptor plates available - contact your Renishaw supplier for details
Measurement range	3-axis measurement: ± 1.25 mm (PX)* / ± 2.5 mm (PY, PZ)*
Overtravel range	PY* and PX* protected by breakout of the kinematic joint to the SH80 PZ* has a mechanical bump stop
Resolution of digital scales	0.02 μ m
Measurement capability test to ISO10360-2**	Typically <1.0 μ m MPE _{THN} with a 60 mm stylus
Scanning capability test to ISO10360-4**	Typically <1.5 μ m MPE _{THN} with a 60 mm stylus Time for scan = 74 s
Return to zero	Approximately 1% of working deflection
Spring rate	Approximately 2.5 N/mm (PX)* Approximately 1.6 N/mm (PY, PZ)*
Stylus carrying capability	Renishaw M5 stylus range Maximum 300 g mass (unbalanced)*** Maximum 500 mm projection #
Mass	SP80H probe body only: 860 g SH80 stylus holder: 185 g KM80 quill mount: 110 g
Pull off force of SH80	<20 N when using SCP80V - otherwise approximately 80 N
Probe power supply	+9 V to +18 V @ 300 mA maximum dc
System power supply (including IU80)	+5 V \pm 0.25 V @ 1 A maximum dc
SP80 probe outputs (X, Y, Z)	1.5 V \pm 0.25 V p-p. analogue quadrature signal (nominal 2.5 V zero crossing reference)
Interfacing options	<ul style="list-style-type: none"> Using Renishaw PCI counter card (CC6) and interpolator unit (IU80) Other interface card designed by OEM and used in conjunction with an IU80 Using a counter card and interpolator units designed by the OEM
Change rack system	SP80V mounted to on OEM supplied extension

SP80 and SP80H user's guide

www.renishaw.com

* Where P specifies that it is the probe's axis rather than the machine's

** Tested on a CMM with specification of $0.48 \mu\text{m} + L/1000$ with touch and scanning deflections $\leq 0.15 \text{ mm}$

*** Stylus centre of gravity to be within area A of graph

Longer stylus lengths may be carried subject to operating conditions - consult Renishaw for application assistance

SP80H specification

Stylus carrying capability

Due to the different orientation of the kinematics problems can occur when trying to support heavy styli on SP80H. Failure to reseat properly after the kinematics have been resealed may be observed with styli that have a moment at the stylus root greater than 200 g at 200 mm.

A graph representing a safe working moment range is shown below; this is based upon stylus weight and centre of gravity (COG) distance from the stylus root. It is advised that where possible customers should try and use styli configurations for SP80H that fall within these guidelines.

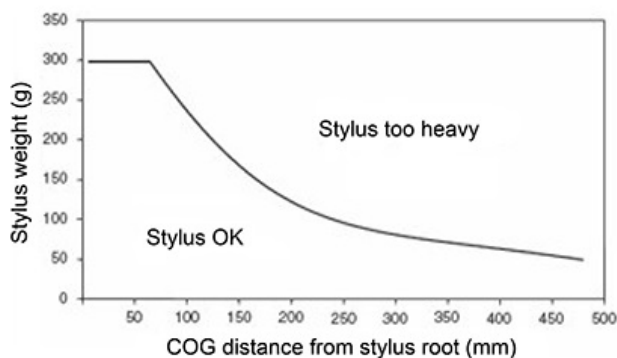

SCP80 stylus change port specification

Parameter	Description
Type of rack	Passive, individual port for interchanging SH80
Mounting	Mounts to the MRS modular rack system Spaced and user definable positions along the length of the MRS
Labels	User applied port number labels
Collision protection	No collision protection in the SCP80 or MRS
Operating orientation	Mounted parallel to the CMM bed
Maximum stylus length	The MRS can be configured to accommodate an SH80 with the 500 mm maximum (vertical) stylus length. Additional MRS legs may be required
Port entry tolerances	CMM positional accuracy of $\pm 0.25 \text{ mm}$
Port lid opening force	2.6 N
Force to detach SH80	<20 N

SP80 and SP80H user's guide

www.renishaw.com

SCP80V stylus change port specification

Parameter	Description
Type of rack	Passive, individual port for interchanging SH80
Mounting	Primarily vertical to be supplied by the OEM Mounts to the MRS modular rack system Spaced and user definable positions along the length of the MRS
Labels	User applied port number labels depending on orientation
Collision protection	No collision protection in the SCP80 or MRS
Operating orientation	Mounted perpendicular to the CMM bed
Maximum stylus length	Refer to graph - SP80H stylus carrying capability
Port entry tolerances	CMM positional accuracy of ± 0.25 mm
Port lid opening force	2.6 N
Force to detach SH80	<20 N

SP80 and SP80H user's guide

www.renishaw.com

System dimensions

Dimensions are shown in mm

SP80 with SH80

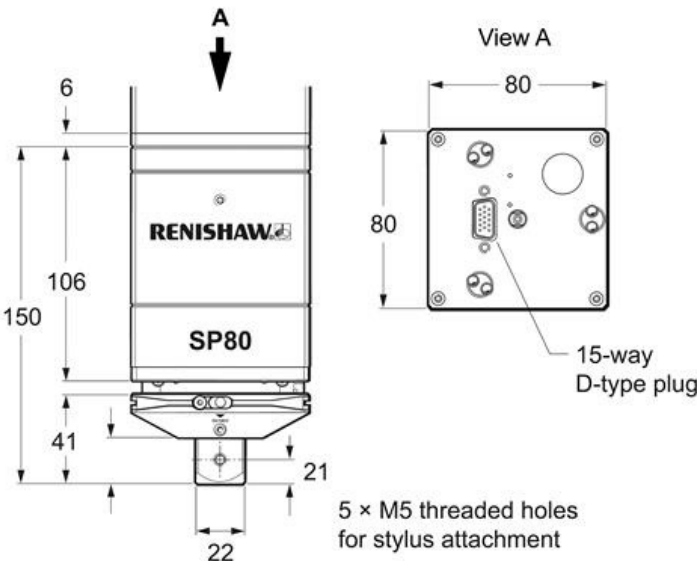

SP80 with SH80K

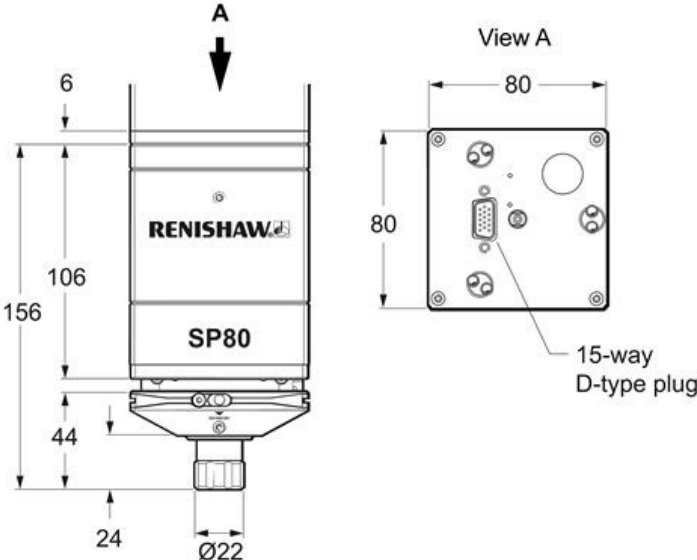

SP80 and SP80H user's guide

www.renishaw.com

KM80

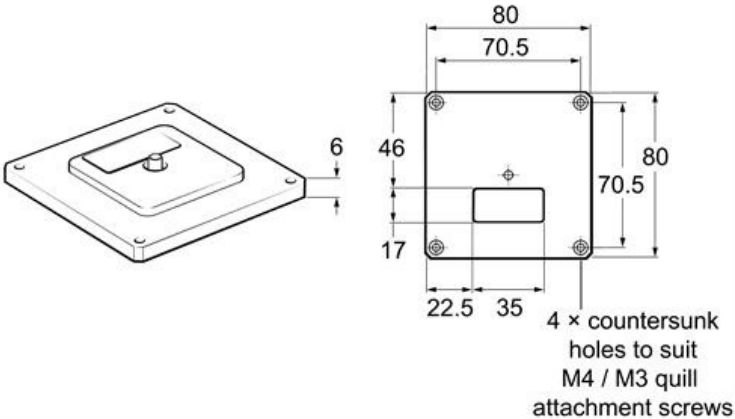

SCP80 / SCP80V

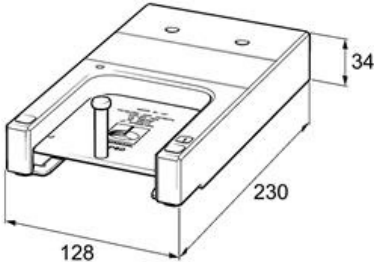

IU80

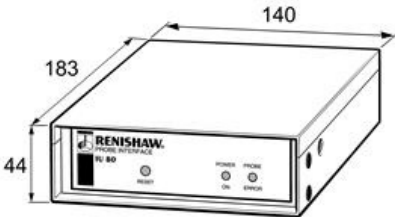

SP80 and SP80H user's guide

www.renishaw.com

System requirements

Electrical requirements

UCC S3 controller

Please refer to the UCC T3 PLUS and UCC S3 installation guide (Renishaw part number H-1000-2118) for safety instructions and documentation relevant to the use of the UCC S3 controller and its subsystems.

UCC PI 80 controller

Please refer to the UCC PI 80 installation guide (Renishaw part number H-1000-7608) for safety instructions and documentation relevant to the use of the UCC PI 80 controller and its subsystems.

CC6 counter card

Please refer to the CC6 Installation and programmer's guide (Renishaw part number H-1000-6008) for safety instructions and documentation relevant to the use of the CC6 counter card.



NOTE: The SP80 and SP80H can be powered by either a connection to a Renishaw UCC S3 controller and UCC PI 80 interface, or an IU80 and CC6 counter card via a PC or an OEM specifically designed system.

Environmental requirements

IU80 interpolator unit

The IU80 complies with (or exceeds) with the following environmental conditions stated in BS EN 61010-1:1993:

Indoor use	IP30
Altitude	Up to 2000 m
Operating temperature	+15 °C to +30 °C
Storage temperature	-10 °C to +70 °C
Relative humidity	80% maximum (non-condensing) for temperatures up to +31 °C Linear decrease to 50% at +40 °C
Transient overvoltages	Installation category II
Pollution degree	2

SP80 and SP80H user's guide

www.renishaw.com

IU80 features and LEDs

Signal interpolation

The IU80 divides the 4 micron periodic signals produced by the SP80 by a factor of 200. This gives a system resolution of 20 nm for each probe axis.

Error signal generation

The IU80 monitors the signals received from the SP80 probe to ensure that each axis readhead is functional. In the event of probe cable damage or unreliable probe signals, an error signal is latched and provides an output via pin 4 of the 26-way connector. A red LED on the IU80 front panel also indicates the same error conditions however, the different errors can be distinguished by an operator looking at the different LED states as detailed in the IU80 LED summary section below. The latch can be reset by either pressing the button on the front panel or applying logic '1' to pin 3 of the 26-way connector.

Probe present signal

The IU80 will detect if an SP80 probe is connected.

If a probe is present, error signals will be enabled and pin 8 of the 26-way plug will be logic '0'.

If a probe is not present, error signals will be disabled and pin 8 of the 26-way output connector will be logic '1'.

IU80 front panel

The front panel of the IU80 has two LED indicators and a reset button.

The green 'POWER ON' LED is illuminated when power is applied to the IU80.

The red 'PROBE ERROR' LED is illuminated if an error has been detected.

The reset button, when pressed, will clear the error condition.

IU80 LED summary

PROBE ERROR LED status	Indication
Permanently off	No error
Permanently on	Probe signal integrity compromised
Flashing	Cable break detected

In the event of an error signal all measurement should be stopped and the probe recalibrated.

SP80 and SP80H user's guide

www.renishaw.com

SP80 LED control

The SP80 probe has a tri-colour LED which can be controlled by the user to act as a visual aid for measurement applications. The LED can be set to red, green or orange depending on the following inputs to pins 9 and 10 of the 26-way 'D' plug.

(Logic '1' = +3 V to +5 V Logic '0' = <0.8 V)

GREEN_LED_OFF (pin 9)	RED_LED_ON (pin 10)	LED colour
0	0	Green
0	1	Orange
1	0	Off
1	1	Red

SP80 and SP80H user's guide

www.renishaw.com

Mounting / removing the SH80 / SH80K on the SP80 / SP80H body

The SH80 incorporates the male half of a magnetic kinematic joint that connects to the female half of the joint on the bottom of both the SP80 and SP80H probe body. The SH80 carries M5 styli, and has a 5-way centre design that can be rotationally adjusted for infinite angle position of the stylus.

Fitting SH80 / SH80K

Fit the SH80 / SH80K into the SH80 removal tool and slowly offer up to the SP80 / SP80H, whilst aligning the triangular alignment marks indicating the front of the probe, and allow the magnetic attraction to make the kinematic joint – the damping mechanism located in the SH80 will ensure a gentle connection. The SH80 tool should also be used to remove the SH80 and SH80K.

Ultimately we recommend that where possible stylus changing is performed automatically to give the best system performance.

Removing the SH80 / SH80K

When removing the SH80 / SH80K manually it is recommended to use the SP80 removal tool, which is supplied as standard with every probe kit.

Slide the removal tool into the grooves on the SH80 / SH80K. Then use the SH80 removal tool to act as a lever.



i **NOTE:** When removing the SH80 manually take care not to twist the unit as this can damage the alignment and damper pins.

SP80 and SP80H user's guide

www.renishaw.com

Mounting styli on the SH80 and styli orientation

Mounting styli on the SH80

It is recommended that the SH80 is removed from the probe body when attaching styli.

M5 stylus arrangements are directly screwed into the 5-way cube on the SH80. Where required, use step down adaptors to smaller thread styli, or select cubes and knuckles to create the required cluster. However wherever possible, M5 styli should be used to ensure the stiffness of construction.

NOTE: Always hold SH80 with your spare hand as the SH80 tool does not retain the SH80.

Styli orientation

The stylus cluster can be rotationally adjusted to its required position by adjustment of the 5-way cube as follows:

1. Releasing the rotational clamping screw using the 2 mm across flats hexagonal key.
2. Rotating the stylus cluster to the required position.
3. Tighten the rotational clamping screw to torque of 1.0 Nm.

Rotational stylus adjustment:

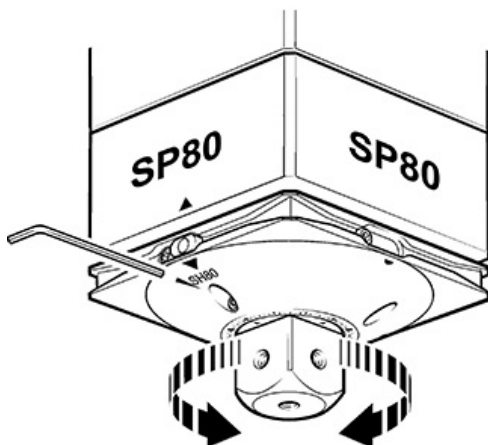

SP80 and SP80H user's guide

www.renishaw.com

Aligning the KM80, KM6080 or SM80 for use with the SCP80(V)

To ensure satisfactory operation with both SCP80 and SCP80V during the change cycle, the KM80, KM6080 quill adaptor plate or SM80 shank mount must be aligned to the CMM axes within the limits shown.

Aligning the KM80 with the CMM axes:

Runout relative to machine axis motion must not exceed 0.1 mm along the edge of the KM80 as shown (or KM6080 / SM80) quill adaptor plates

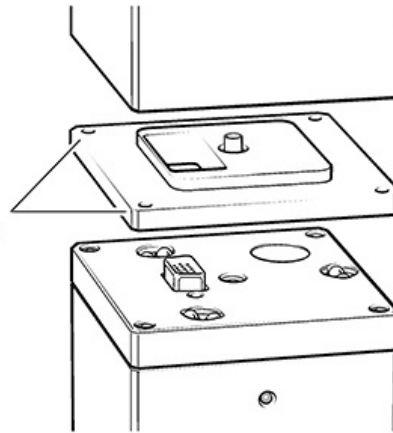

SP80 and SP80H user's guide

www.renishaw.com

Fitting the SCP80 / SCP80V to the MRS / MRS2 rack system

Fitting SCP80 to the MRS rail

The SCP80 change ports can be fixed to an MRS or MRS2 rack system. It is recommended that they are attached to the MRS / MRS2 rail using the following procedure, where it is assumed that the MRS / MRS2 rack system is correctly installed.

Installation procedure

1. Loosely assemble the T-nuts and bolts [4] to the mounting holes in the SCP80 [3] *.
2. Offer up the SCP80 [3] to the MRS rail [1] and align the T-bolts with the slot on the underside of the rail.
3. Slide the SCP80 onto the rail to the desired position, ensuring that sufficient operating clearance exists to carry out all SH80 docking routines.
4. Using the hexagonal key supplied, hand-tighten the T-nuts and bolts.
5. Align the SCP80 to the CMM axes, as described in '[Alignment of the SCP80\(V\) to the CMM axes](#)', before finally tightening it to the MRS rail.
6. Fit end caps to the MRS rail.

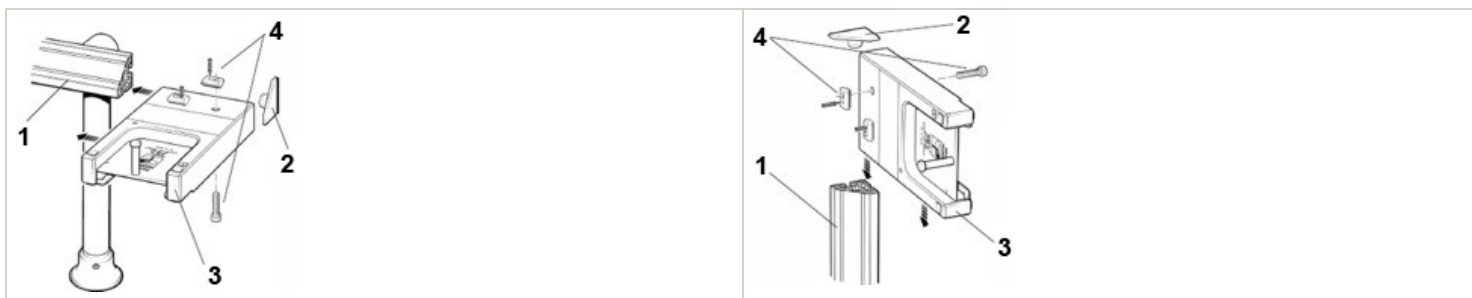

Key	Description
1	MRS / OEM rail
2	End cap
3	SCP80 / SCP80V
4	T-nuts and bolts *

i **NOTE:** SCP80V will fit to MRS using the same method. The rail for SCP80V is supplied by the OEM and may look different to that illustrated.

i * **NOTE:** T-nuts must be used with the MRS system. However T-nuts and D-nuts are compatible with the MRS2 system.

SP80 and SP80H user's guide

www.renishaw.com

Alignment of SCP80(V) to the CMM axes

Alignment of the SCP80 to the CMM axes

The alignment of the SCP80 to the CMM axes should be checked to be within the limits shown below.

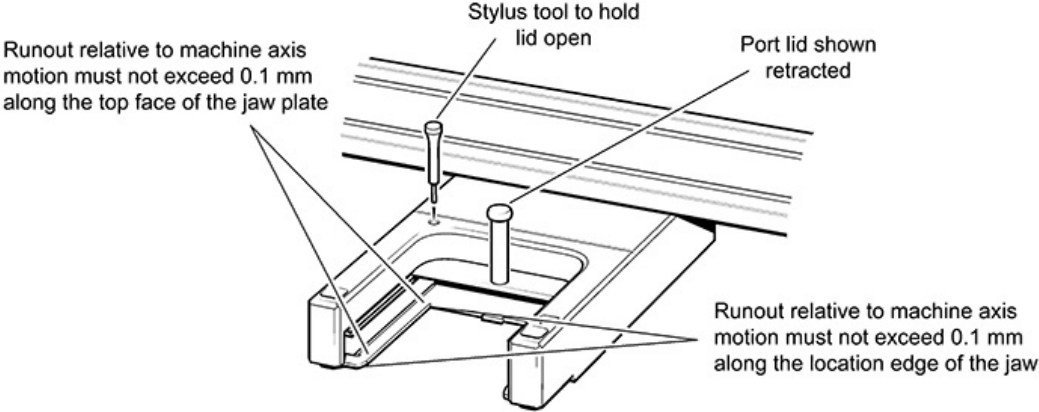

Alignment of the SCP80V to the CMM axes

The alignment of the SCP80V to the CMM axes should be checked to be within the limits shown below.

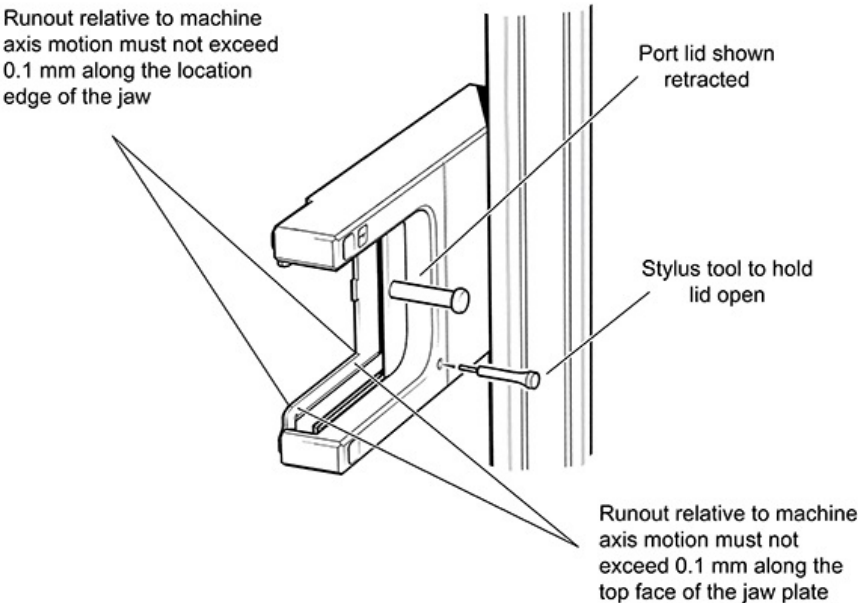

SP80 and SP80H user's guide

www.renishaw.com

Establishing SCP80(V) port datums

The following section describes the recommended procedure for datuming each installed SCP80(V) port. Before commencing the following should have been completed:

- The SCP80(V) ports should have previously been fitted to the MRS rail (or extrusion) and aligned to the CMM axes
- The SP80 / SP80H probe should have been correctly installed, aligned and fitted with a suitable M5 stylus
- The probe and stylus should have been calibrated and made ready to take single point measurements

i NOTE: The examples given here assume that the MRS / SCP80 rack system is aligned to the X-axis of the CMM, being along the rear of the working area.

Procedure for establishing the port datum for SCP80 and SCP80V

Both rack port types use the same procedure just in different orientations. The following routine should be completed using manual CMM control.

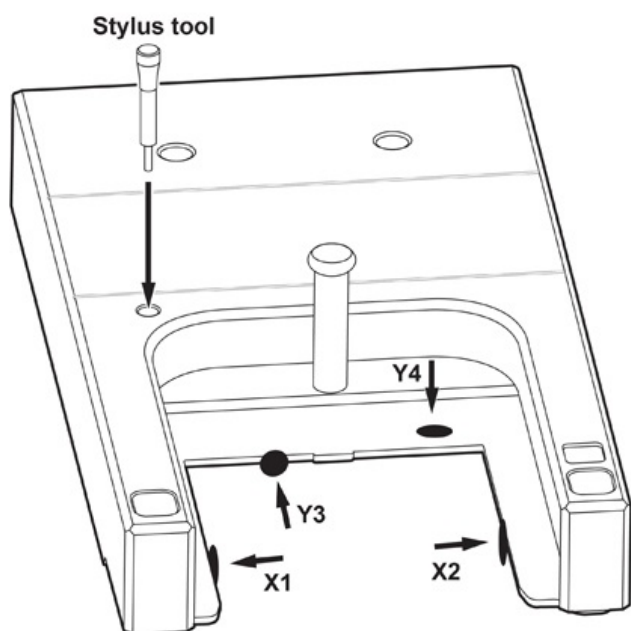

1. Open the port lid to the extreme of travel and place a stylus tightening tool or similar object into the retaining hole to keep it in place.
2. Take 4 points on the jaw plate as follows:

- Take points 1 and 2 across the central jaw and record X1 and X2 values
- Take point 3 at the rear edge and record the Y3 value
- Take point 4 on the top face of the jaw plate (take care not to hit the post on the rack lid) and record the Z4 value

SP80 and SP80H user's guide

www.renishaw.com

3. Create the X and Y port datums as follows:

- $X \text{ origin} = (X1 + X2)/2$
- $Y \text{ origin} = Y3 - 41.5 \text{ mm} + (\text{stylus tip diameter}/2)^*$
- Store the datums then assign them, and the port, an identification number

4. Create the Z port datum using one of the following methods:

The Z origin must be created in a way that enables satisfactory changing of the SH80 in the SCP80 over the entire stylus range (mass) that the SP80 can carry. This range is from 33 g to 500 g with the effect that 'droop' increases with mass.

METHOD 1 (preferred)

This method will ensure the SH80 enters the docking slot of SCP80 such that the docking features are centrally aligned in the Z axis.

- Using the port calibration stylus supplied with the probe kit, the probe should be nulled. A temporary Z port datum should be calculated as follows:
 $\text{Temporary Z origin} = Z4 - (\text{stylus length} + (\text{stylus tip diam}/2)^* + 38 \text{ mm})$
- Then for all other stylus configurations, with differing mass, the Z port datum should be calculated as follows:
 $Z \text{ origin} = Z4 - (\text{stylus length} + (\text{stylus tip diam}/2)^* + 38 \text{ mm} - \text{ZOFFSET})$
 (Where ZOFFSET is the value of any Z axis droop observed with heavier styli mass).
- Store the datum then assign it, and the port, an identification number.

METHOD 2 (non-preferred)

This method is simpler to use and merely uses a constant ZOFFSET value which will allow any stylus configuration within the SP80 carrying range of 33 g to 500 g to be docked.

However, the user will notice the following characteristics during docking when using this method: with lighter styli the SH80 will be seen to pull downward, and with heavier styli the SH80 will be seen to pull upward.

- Using the port calibration stylus supplied with the probe kit, the Z port datum should be calculated as follows:

$$Z \text{ origin} = Z4 - (\text{stylus length} + (\text{stylus tip diam}/2)^* + 37 \text{ mm})$$

- Store the datum and assign it, and the port, an identification number

* Assuming no tip compensation when measuring.

SP80 and SP80H user's guide

www.renishaw.com

Put down and pick up routines for SH80

The recommended pick up and put down routines are detailed below and consist of driving sequentially through four positions. These apply to both SP80 and SP80H.

 **NOTE:** The speed of motion during the change cycle should be restricted to 20 mm/s maximum.

Put down routine for SH80 / SCP80 or SCP80V

Move description	Offsets orientated to the probe axes PX	Offsets orientated to the probe axes PY	Offsets orientated to the probe axes PZ
Move to the clearance position	PX=0	PY=100	PZ=0
Inhibit the probe			
Reduce CMM speed to 20 mm/sec max			
Move to the port datum position	PX=0	PY=0	PZ=0
Detach the SH80	PX=0	PY=0	PZ=30
Pause for the port to reset - 3 sec min			
Exit port to the clearance position	PX=0	PY=100	PZ=30
Restore normal CMM drive speed			

SP80 and SP80H user's guide

www.renishaw.com

Pick up routine for SH80 / SCP80 or SCP80V

Move description	Offsets orientated to the probe axes PX	Offsets orientated to the probe axes PY	Offsets orientated to the probe axes PZ
Move to the clearance position	PX=0	PY=100	PZ=30
Reduce CMM speed to 20 mm/sec max			
Move into the port pick up position	PX=0	PY=0	PZ=30
Attach the SH80	PX=0	PY=0	PZ=0
Pause for the SH80 to clasp - 3 sec min			
Exit port to the clearance position	PX=0	PY=100	PZ=0
Restore normal CMM drive speed			
Activate the probe			

SP80 and SP80H user's guide

www.renishaw.com

Put down and pick up routine for SH80K with SP80

Put down routine for SH80K and SP80

Move description	Offsets orientated to the probe axes PX	Offsets orientated to the probe axes PY	Offsets orientated to the probe axes PZ
Move to the clearance position	PX=0	PY=100	PZ=3
Inhibit the probe			
Reduce CMM speed to 20 mm/sec max			
Move to the port datum position	PX=0	PY=0	PZ=3
Detach the SH80K	PX=0	PY=0	PZ=30
Pause for the port to reset - 3 sec min			
Exit port to the clearance position	PX=0	PY=100	PZ=30
Restore normal CMM drive speed			

Pick up routine for SH80K and SP80

Move description	Offsets orientated to the probe axes PX	Offsets orientated to the probe axes PY	Offsets orientated to the probe axes PZ
Move to the clearance position	PX=0	PY=100	PZ=30
Reduce CMM speed to 20 mm/sec max			
Move into the port pick up position	PX=0	PY=0	PZ=30
Attach the SH80K	PX=0	PY=0	PZ=3
Pause for the SH80K to clasp - 3 sec min			
Exit port to the clearance position	PX=0	PY=100	PZ=3
Restore normal CMM drive speed			
Activate the probe			

SP80 and SP80H user's guide

www.renishaw.com

Put down and pick up routine for SH80K with SP80H

Put down routine for SH80K and SP80H

Move description	Offsets orientated to the probe axes PX	Offsets orientated to the probe axes PY	Offsets orientated to the probe axes PZ
Move to the clearance position	PX=0	PY=100	PZ=2.5
Inhibit the probe			
Reduce CMM speed to 20 mm/sec max			
Move to the port datum position	PX=0	PY=0	PZ=2.5
Detach the SH80K	PX=0	PY=0	PZ=30
Pause for the port to reset - 3 sec min			
Exit port to the clearance position	PX=0	PY=100	PZ=30
Restore normal CMM drive speed			

Pick up routine for SH80K and SP80H

Move description	Offsets orientated to the probe axes PX	Offsets orientated to the probe axes PY	Offsets orientated to the probe axes PZ
Move to the clearance position	PX=0	PY=100	PZ=30
Reduce CMM speed to 20 mm/sec max			
Move into the port pick up position	PX=0	PY=0	PZ=30
Attach the SH80K	PX=0	PY=0	PZ=2.5
Pause for the SH80K to clasp - 3 sec min			
Exit port to the clearance position	PX=0	PY=100	PZ=2.5
Restore normal CMM drive speed			
Activate the probe			

SP80 and SP80H user's guide

www.renishaw.com

Modes of operation

Qualification (calibration of the probe)

The SP80 and SP80H probes require qualification (calibration) before it is able to give accurate positional data. After the probe and stylus combination is calibrated it can be used in a variety of ways. Principally these will be as either a single point measurement probe or a profile measurement-scanning probe. Please refer to the modes below.

Scanning mode

SP80 and SP80H can be used as a continuous deflection contact scanning probe for profile measurement or for surface digitising purposes. In this case the CMM controller must respond to the deflections of the probe in real time to maintain surface contact.

Single point measurement mode

The following are methods that can be used for taking single point measurements using a calibrated SP80 or SP80H. OEMs are advised to evaluate each of these to determine the best solution for their own system.

Static averaging method

SP80 and SP80H can be used to take single points to give increased accuracy whilst reducing the effects of machine vibration by performing static averaging.

The probe stylus should be made to contact the workpiece and deflect the stylus to the recommended amount (50 μm). The CMM should be halted and kept nominally stationary.

Whilst the machine is stationary, surface position readings should be taken which are then averaged to give one single surface point. The longer the system is kept stationary, the more readings can be gathered to give a more accurate result and to average out the effect of machine vibration.

Extrapolate to zero method

Data is acquired whilst in contact and moving normal to the surface, either on the way in or whilst backing off. This is extrapolated to zero probe displacement position. It has the advantage that the measurement takes place at zero force, minimising the deflection on probe, stylus and CMM, and additionally is less sensitive to probe calibration.

SP80 and SP80H user's guide

www.renishaw.com

Threshold methods

There are two types of threshold method as described below. Type 1 takes data whilst driving the probe onto the part to a pre-set deflection threshold, whilst type 2 takes data whilst backing off to the pre-set deflection threshold.

Type 1

A target deflection threshold should be set. The probe is driven onto the part until this target deflection threshold is seen, at which time the controller simultaneously stores all CMM axes together with the probe deflections - this is the data point.

Type 2

A target deflection should be set. Additionally, an upper target deflection should be set which will enable a back off move to the target deflection to be executed at a constant velocity. The probe is driven onto the part until the upper target deflection is seen, at which time the motion should halt and a back off move should commence. When the target deflection is seen, the controller simultaneously stores all CMM axes together with the probe deflections - this is the data point.

SP80 and SP80H user's guide

www.renishaw.com

SP80 and SP80H stylus selection

 **NOTE:** For more detailed information about the range of Renishaw styli please refer to the styli and accessories technical specifications booklet (Renishaw part number H-1000-3200).

Of particular interest to SP80 and SP80H users is M5 styli section. This details not only an extensive range of M5 styli that are compatible with the SP80 and SP80H, but also includes a complete range of carbon fibre extension bars of 11 mm or 20 mm diameter, and up to 500 mm long.

Accuracy at the point of contact

As industry has developed its requirement for increasingly diverse and complex manufactured parts, inspection systems have had to work hard to keep up. The use of CMMs with probing systems and in-process inspection on machine tools are two of the solutions offered by Renishaw to help you maximise your productivity and maintain the highest possible standards of quality.

Successful gauging depends very much on the ability of the probe's stylus to access a feature and then maintain accuracy at the point of contact. At Renishaw, we have used our expertise in probe and stylus design to develop a comprehensive range of CMM styli to offer you the greatest possible precision.

These notes explain the critical features of each stylus type, helping you to choose the right design for each inspection need.

What is a stylus?

A stylus is that part of the measuring system which makes contact with the component, causing the probe mechanism to displace. The generated signal enables a measurement to be taken. The feature to be inspected dictates the type and size of stylus used. In all cases, however, maximum rigidity of the stylus and perfect sphericity of the tip are vital.

The performance of your gauging can easily be degraded if you use a stylus with poor ball roundness, poor ball location, bad thread fit or a compromised design that allows excessive bending during measurement. To ensure the integrity of the data you gather, make certain that you specify and use a stylus from the comprehensive range of genuine Renishaw styli.

Best practice when using a stylus

In order to maintain accuracy at the point of contact we recommend that you:

- Keep styli short
- Minimise joints
- Maximise stem diameter and stylus ball size where possible
- Regularly inspect stylus tips for wear or damage

SP80 and SP80H user's guide

www.renishaw.com

Ball materials available with Renishaw styli

Ruby

The industry standard and the optimum stylus ball material for a vast majority of measurement applications, ruby is one of the hardest known materials. Synthetic ruby is 99% pure aluminium oxide, which is grown into crystals (or 'boules') at 2000 °C using the Verneuil process.

The boules are then cut and gradually machined into a highly spherical form. Ruby balls are exceptionally smooth on the surface, have great compressive strength and a high resistance to mechanical corrosion.

Very few applications exist where ruby is not the best ball material, however there are two such applications where balls manufactured from other materials are recommended.

Silicon nitride

The first is for heavy duty scanning applications on aluminium. Because the materials attract, a phenomenon known as 'adhesive wear' can occur which involves build up of aluminium from the surface onto the ball. A better ball material for such applications is silicon nitride.

Silicon nitride possesses many similar properties to ruby. It is a very hard and wear resistant ceramic which can be machined into very high precision spheres. It can also be polished to an extremely smooth surface finish. Silicon nitride does not have the attraction to aluminium and so does not exhibit the adhesive wear seen with ruby in similar applications. Silicon nitride does, however, show significant abrasive wear characteristics when scanning on steel surfaces so its applications are best confined to aluminium.

Zirconia

The second circumstance where ruby may be problematic is once again in heavy duty scanning applications on cast iron. Interaction between the two materials can result in 'abrasive wear' of the ruby ball surface. For such applications, zirconia balls are recommended.

Zirconia is a particularly tough ceramic material with hardness and wear characteristics approaching those of ruby. Its surface properties, however, make it an ideal material for aggressive scanning applications on cast iron components.

SP80 and SP80H user's guide

www.renishaw.com

Stem material available with Renishaw styli

Steel

Stems manufactured from non-magnetic stainless steel are used widely for styli with ball/tip diameters of 2 mm or greater and with lengths up to 30 mm. Within this range, one-piece steel stems offer the optimum stiffness to weight ratio, giving adequate ball/stem clearance without compromising stiffness with a joint between the stem and threaded body.

Tungsten carbide

Tungsten carbide stems are best used for maximising stiffness with either small stem diameters, required for ball diameters of 1 mm and below, or over longer lengths up to 50 mm. Beyond this, weight can become a problem or stiffness is lost due to deflection at the stem-to-body joint.

Ceramic

For ball diameters greater than 3 mm, and lengths over 30 mm, ceramic stems offer stiffness comparable to steel, and are significantly lighter in weight than tungsten carbide. Ceramic stemmed styli can also offer additional crash protection to your probe as the stem will shatter in a collision.

Carbon fibre (Renishaw GF)

There are many grades of carbon fibre materials, however Renishaw GF combines optimum stiffness characteristics, both longitudinally and in torsion (important in star constructions) with extremely low weight. Carbon fibre is inert and this, combined with a special resin matrix, provides excellent protection in the most hostile machine tool environments.

Renishaw GF is ideal for maximising stiffness while giving very low mass for styli above 50 mm in length. It is the optimum stem material for high accuracy strain gauge technology probes with excellent vibration damping characteristics and negligible co-efficient of thermal expansion.

SP80 and SP80H user's guide

www.renishaw.com

Maximising performance

Calibration

The probe and stylus must be calibrated correctly. Renishaw has extensive experience of scanning and offers support and advice on calibration algorithms and control software suited to SP80. Please contact Renishaw for further information.

Probe deflection

Scanning deflections should be kept small, as the machine settings and application will allow loads on the probe, stylus and CMM quill to be minimised.

The probe must be operated within its calibrated deflection range. For best performance, take measurements at the mid-point of the calibration deflection limits. It is recommended that the probe is calibrated at deflections of 0.2 mm and 0.8 mm, with best measurement data then achieved at 0.5 mm.

Touch / scan speed

Performance will vary with probe speeds:

- Longer heavy stylus combinations will require slower speeds
- Generally, best performance is obtained at speeds less than 10 mm/sec
- Avoid abrupt changes to CMM speed while taking measurements

Cleanliness

Ensure both stylus and workpiece are clean.

CMM maintenance

- Ensure that the CMM has been correctly maintained and has been corrected for geometrical errors such as axis squareness, pitch, roll and yaw etc
- Ensure that the CMM has an error map which is up to date and enabled in the control system
- Check the system accuracy from time to time by running an ISO 10360-4 test or other similar routine
- Regularly check the volumetric measuring performance of the CMM by using Renishaw's MCG machine checking gauge

Stylus selection

Refer to web page [SP80 and SP80H stylus selection](#) for detail.

SP80 and SP80H user's guide

www.renishaw.com

SP80 and SP80H maintenance

The SP80 / SP80H probe is a serviceable part. In the event of a problem, please contact your supplier for assistance.

Following the simple maintenance procedures given below will prolong the operational life and continued high performance of the system. The user should determine the frequency of inspection and maintenance actions according to the conditions of use.



CAUTION: Always adhere to the safety instructions given in this guide. Failure to do so could adversely affect the performance of the probe and / or lead to personal injury.

SP80 and SP80H probe bodies and stylus holders (SH80 and SH80K)

The external surfaces of all system components should only be cleaned using a soft, lint free cloth. All parts must always be kept dry.

The kinematic coupling mechanisms, incorporated throughout the system, have a precision ball-on-ball seating, electrical contacts and permanent magnets. The coupling has been tested in a wide variety of environments and is highly tolerant of non-metallic dust, but regular inspection and cleaning is recommended to ensure continued high performance of the probe system.

Renishaw supplies a kit for easy cleaning of the kinematic coupling, which is available from your local Renishaw supplier, part number A-1085-0016.

SCP80(V) stylus changing port

Periodic cleaning of the ports, lids and outer surfaces, using a soft lint free cloth, is recommended to prevent contamination of stored stylus holders.

Styli

Stylus balls, threads and mating faces should be cleaned using a proprietary cleaning cloth or solvent such as isopropyl alcohol. Stylus balls should be regularly inspected for damage or 'pick-up' of component material (a problem sometimes encountered with continuous scanning).

Renishaw plc
New Mills, Wotton-under-Edge
Gloucestershire, GL12 8JR
United Kingdom

T +44 (0)1453 524524
F +44 (0)1453 524901
www.renishaw.com/cmmsupport



**For worldwide contact details,
please visit our main website at
www.renishaw.com/contact**